

PM 280	
Caudal a 900 R.P.M Débit à 900 R.P.M Flow rate at 900 R.P.M	280 l/min
Cilindrada Cylindrée Capacity	311.11 cc/v
R.P.M Max.	1500
Presión máxima Pression maxi Max.Presure	10 Bar
Temperatura máxima Température maximale Maximum temperature	100°C
Sentido de giro Sens de rotation Turning direction	Independiente Indépendant Independent

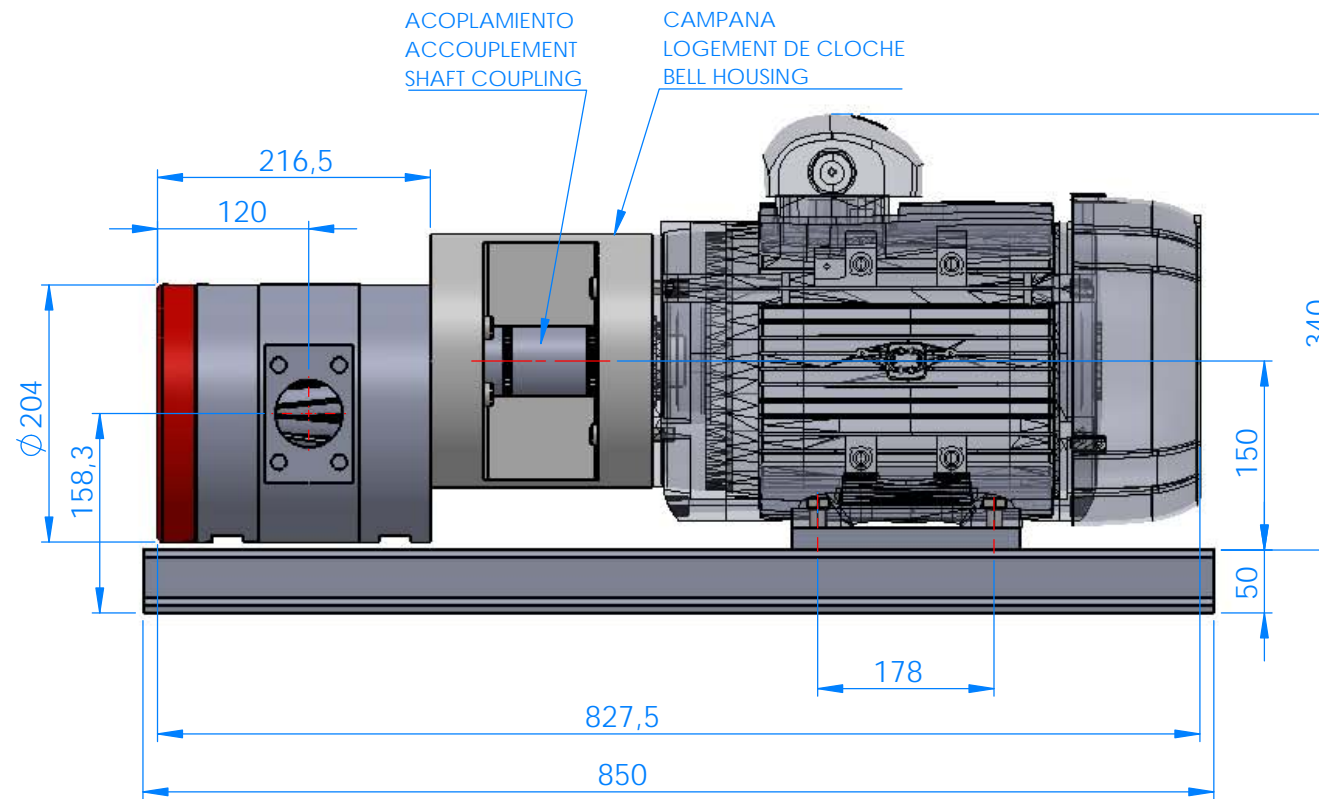

Motor B14	
Velocidad Vitesse Speed	900 R.P.M
Potencia Puissance Power	5.5 C.V - 4 Kw
Tensión Tension Tension	230-400V
Tipo Type Type	IEC 132 M

