

PM66	
Caudal a1500 R.P.M Débit à 1500 R.P.M Flow rate at 1500 R.P.M	66 l/min
Cilindrada Cylindrée Capacity	44 cc/v
R.P.M Max.	1500
Presión máxima Pression maxi Max.Presure	10 Bar
Temperatura máxima Température maximale Maximum temperature	100°C
Sentido de giro Sens de rotation Turning direction	Independiente Indépendant Independent

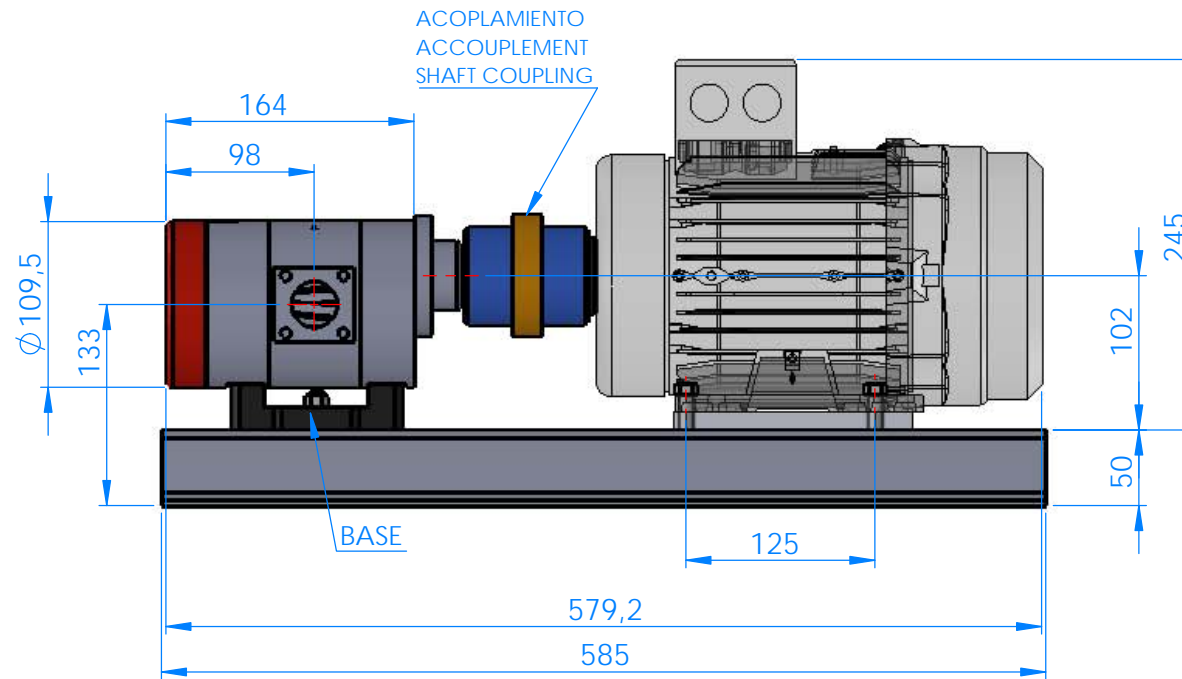

Motor B3	
Velocidad Vitesse Speed	1500 R.P.M
Potencia Puissance Power	2C.V - 1.5 KW
Tensión Tension Tension	230-400V
Tipo Type Type	IEC-90 L

