

PM 100	
Caudal a 1500 R.P.M Débit à 1500 R.P.M Flow rate at 1500 R.P.M	100 l/min
Cilindrada Cylindrée Capacity	66.6 cc/v
R.P.M Max.	1500
Presión máxima Pression maxi Max.Presure	10 Bar
Temperatura máxima Température maximale Maximum temperature	100°C
Sentido de giro Sens de rotation Turning direction	Independiente Indépendant Independent
Peso Poids Weight	13.8 Kg

Materiales/Matériau/Material	
Cuerpo y tapas Corps et couvercles Body and covers	Inox AISI 316 Inox AISI 316 S.S AISI 316
Ejes Axes Shaft	Inox AISI 316 Inox AISI 316 S.S AISI 316
Engranajes Engrenages Gears	Inox AISI 420/PEEK Inox AISI 420/PEEK S.S AISI 420/PEEK
Casquillos Casquettes Bushings	Grafito/PEEK Graphite/PEEK Graphite/PEEK
Elastómeros Élastomères Elastomers	Vitón Viton Viton
Cierre mecánico Garniture mécanique Mechanical seal	Csi, Csi, Viton
Camara de calentamiento Chambre de chauffage Heating chamber	Aluminio Aluminium Aluminium

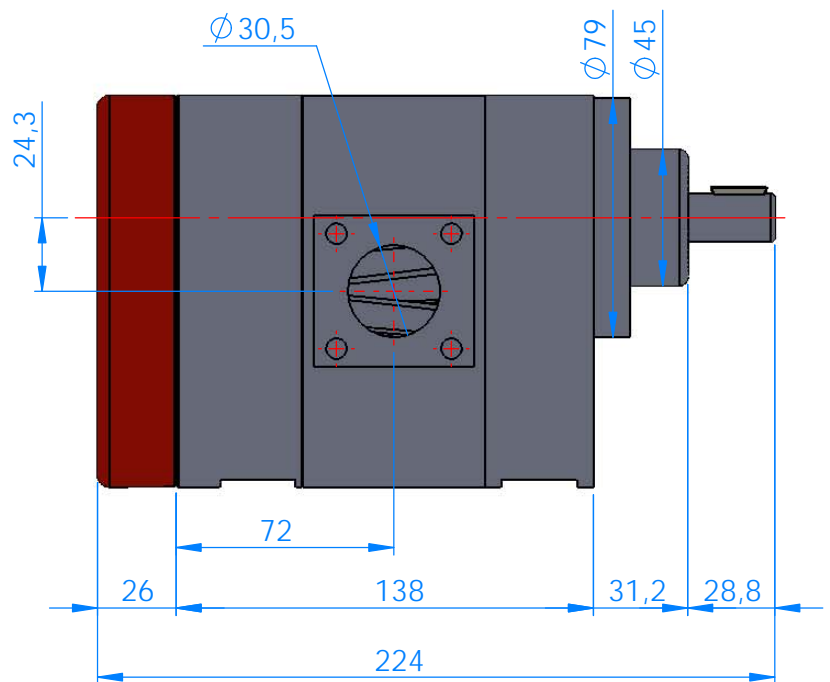

Chaveta DIN 6888  $\phi$  19X4  
Goupille de sécurité DIN 6888  $\phi$  19X4  
Cotter pin DIN 6888  $\phi$  19X4

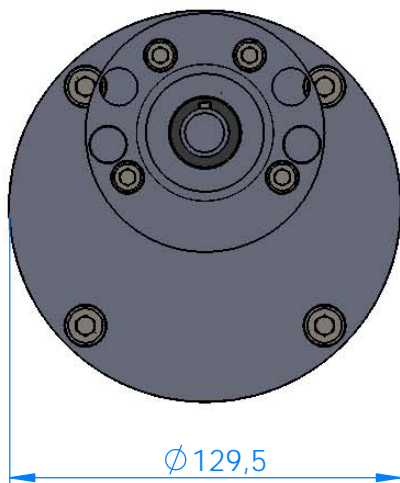