

BOMBA DE ENGRANAJES
POMPE À ENGRENAGES
GEAR PUMPS

ANGLADA
PUMPS MACHINING GEAR BOXES

BQ-300+MOTOR

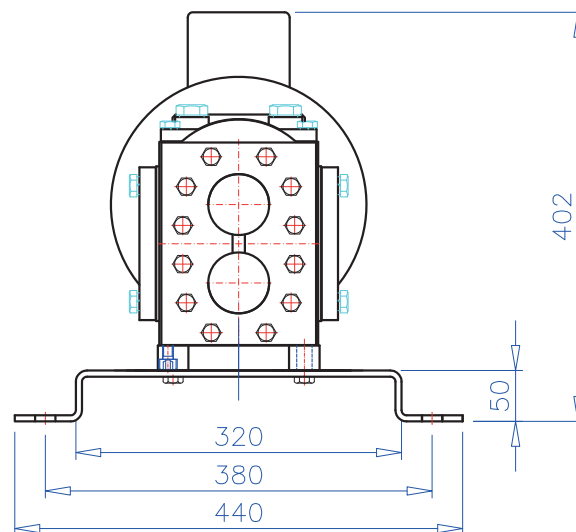
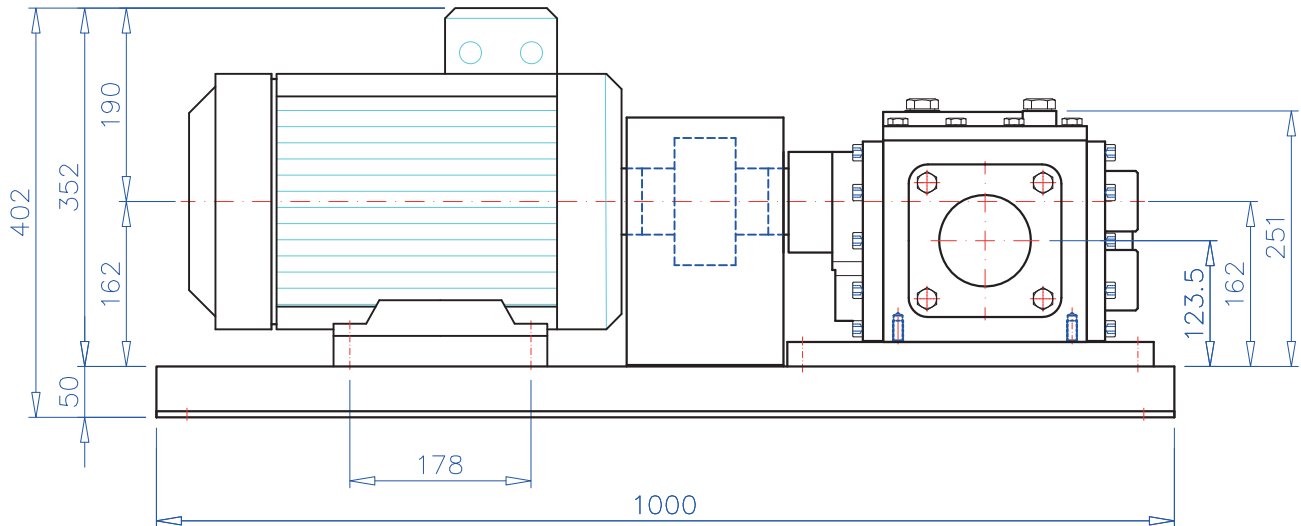

CARACTERÍSTICAS DE LA BOMBA

Caudal a 1500 R.P.M	26.000 L/H
Débit à 1500 R.P.M	17.000 L/H
Flow rate at 1500 R.P.M	
Cilindrada	680 Cm3/v
Cylindrée	
Capacity	
Rpm max (standard versión)	1500
Presion Maxima	10bar
Pression maxi	
Max.Presure	
Temperatura máxima	80°C
Température maximale	
Maximum temperature	
Sentido de giro	Dependiente
Sens de rotation	Dépendant
Turning direction	Dependent

CARACTERÍSTICAS DEL MOTOR

Velocidad	1500 R.P.M
Vitesse	
Speed	
Potencia	10 C.V - 7.5 KW
Puissance	
Power	
Tensión	380-420V
Tension	
Tension	
Tipo	IEC-132M B3
Type	
Type	